



zoneguard™

Ultimate protection for installers, roadworkers, and drivers



Safe

Positive protection, accepted by the FHWA as meeting recognized crash test standards

Easy

Connection of the portable barrier system units requires no hand tools

Fast

Longer and Lighter units means more efficient delivery and faster installation

Effective

Deflection comparable to traditional portable barrier systems

www.hillandsmith.com | 614.340.6294



Made in the U.S.A.



Hill and Smith, Inc. has developed a durable portable steel traffic barrier, designed to protect highway travelers, as well as road and construction crews. Traditional portable barrier systems are costly, heavy to transport and handle, time-consuming and do not provide the energy-absorbing capabilities of Zoneguard. Today's Engineers and DOT's have a responsibility to provide the utmost safety to the driving public, while meeting tight budgets and timelines. Zoneguard offers the maximum safety standards, while ensuring cost-effective and efficient protective barriers.



zoneguard SAFE

Zoneguard has been extensively tested to US as well as European crash test standards, and has been accepted by the FHWA as meeting NCHRP 350 and MASH-08 TL-3 and TL-4. More footage per truck means truck entries to and exits from the work zone are reduced by over 80%.

zoneguard EASY

Zoneguard can be easily transported to any job. Each lightweight 50'-0" section weighs just over 3000 lbs., enabling 750 feet to be efficiently transported on one truck.

Zoneguard can be easily and quickly placed into position and connected with standard construction equipment. Our Speed Joint system allows for quick connections with no hand tools.

zoneguard FAST

Zoneguard's configuration and light weight enable 750 feet to be shipped on one truckload and means that jobs can be completed more efficiently and economically by reducing the number of trucks required, and therefore, overall fuel consumption and trucking costs.

Zoneguard can be installed at the rate of 1000 ft per hour, making it one of the most efficient positive protection methods available.

zoneguard EFFECTIVE

Zoneguard's rigid cross-section, and low center of gravity enables deflections which are comparable to heavier traditional portable barrier systems.

Zoneguard's unique base can allow for application of striping to eliminate need for temporary striping.

Standard 50'-0" Zoneguard units can be installed on curves down to 800' radius. Special units can be provided for tighter curves, as well as flared sections.

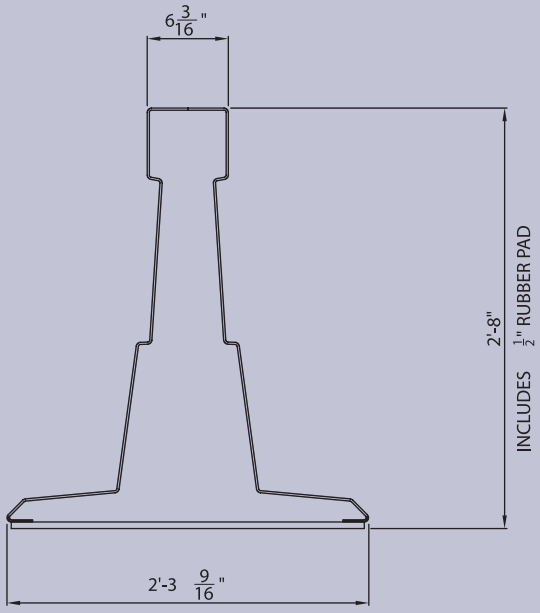

General System Specifications:

Performance:

- Tested & accepted by FHWA to NCHRP 350 and MASH 08 TL-3 and TL-4
- Standard System anchored at ends only
- Minimum Deflection System anchored every 33'-4"
- Deflection values comparable to traditional portable barrier systems

Materials:

- Structural Steel, galvanized to ASTM A123
- All steel melted and manufactured in the USA
- All fabrication and galvanizing performed in the USA

Dimensions:

Height:	2'-8" including 1/2 inch rubber pad
Width at base	2'-3 9/16"
Standard unit length:	50'-0"
Weight of standard unit:	3,004 lbs.

ZONEGUARD — Key Features

- NCHRP 350 & MASH-08 TL3 & TL-4 performance
- Temporary or Permanent positive protection
- Lightweight - less than 61 pounds per foot
- Fast, Effective Delivery - 750 feet per truck
- Quick Installation - up to 1000 feet per hour
- 1/2" thick rubber pad on foot section allows for water drainage off road surface
- Tested, Fabricated, Galvanized & Assembled in the USA



zoneguard™

Ultimate protection for installers, roadworkers, and drivers



Zoneguard™ is the most extensively tested, and the most cost efficient portable positive protection system available in the United States. Contact your local Hill & Smith sales representative today for more information.

Hill & Smith, Inc.
1000 Buckeye Park Rd.
Columbus, OH 43207

Phone: 614.340.6294
Fax: 614.340.6296
info@hillandsmith.com
www.hillandsmith.com



HILL & SMITH, Inc.